

To: M/s _____

Subject: **Tender Inquiry Procurement of Components / Material for Distribution Box**

1. You are requested to please forward your offer for following:-

Ser	Part No	Nomenclature	A/U	Quantity Required	Remarks
1.	MZJ-200A/006 or equivalent	DC Contactors Country of Origin: China or equivalent Specification: <ul style="list-style-type: none"> Rated Voltage: 24V DC Peak Voltage: 30V DC Coil Resistance: 68 Ohms Pick up time: ≤ 30ms Release time: ≤ 30ms Max Switching Current: 200A Ambient temperature: -40°C ~ +70°C 	Nos	50	
2.	P600D	DIODE Country of Origin: China or equivalent Specification: <ul style="list-style-type: none"> Max repetitive peak voltage: 200V $I_{F(AV)} = 6 \text{ A}$ $I_{FSM} = 400 \text{ A}$ Max DC blocking voltage: 200V Reverse recovery time: 2.5 μs $T_J \text{ Max: } 150 \text{ }^\circ\text{C}$ 	Nos	50	
3.	AFP-200 1.5mm ²	Wire Country of Origin: China or equivalent Specification: <ul style="list-style-type: none"> Temperature Rating: 200°C Silver Plated Shielded Wire 	Mtr	20	
4.	Nil	Material / Tools for fabrication of Sensor's body Country of Origin: Pakistan or equivalent Specification: <ul style="list-style-type: none"> Aluminum block (275 x 180 x 110 mm³) 	Nos	28	
5.	Nil	Material / Tools for fabrication of Sensor's body Country of Origin: Pakistan or equivalent Specification: <ul style="list-style-type: none"> MS Steel Plate(4 x 8 ft) Thickness: 8mm 	Nos	02	

6.	Nil	Material / Tools for fabrication of Sensor's body Country of Origin: Pakistan or equivalent Specification: <ul style="list-style-type: none"> • MS Steel Plate(4 x 8 ft) • Thickness: 2mm 	Nos	02	
7.	Nil	Material / Tools for fabrication of Sensor's body Country of Origin: Pakistan or equivalent Specification: <ul style="list-style-type: none"> • Copper Sheet (2 x 4 ft) • Thickness: 1.5mm 	Nos	02	
8.	Nil	Material / Tools for fabrication of Sensor's body Country of Origin: Pakistan Specification: <ul style="list-style-type: none"> • Brass Sheet(2 x 4 ft) • Thickness: 1.5mm 	Nos	02	
9.	Nil	Material / Tools for fabrication of Sensor's body Country of Origin: Pakistan or equivalent Specification: <ul style="list-style-type: none"> • Brass Sheet(2 x 4 ft) • Thickness: 3.3 mm 	Nos	02	
10.	Nil	Material / Tools for fabrication of Sensor's body Country of Origin: Pakistan or equivalent Specification: <ul style="list-style-type: none"> • Bakelite Sheet(2 x 4 ft) • Thickness: 18 mm 	Nos	01	
11.	Nil	Material / Tools for fabrication of Sensor's body Country of Origin: Pakistan or equivalent Specification: <ul style="list-style-type: none"> • Hex Rod Brass • Hex =10mm, Length=1000mm 	Nos	04	
12.	Nil	Material / Tools for fabrication of Sensor's body Country of Origin: Pakistan or equivalent Specification: <ul style="list-style-type: none"> • Rod Brass • Dia=30 mm, Length=1000mm 	Nos	05	
13.	Nil	Material / Tools for fabrication of Sensor's body Country of Origin: Pakistan or equivalent Specification: <ul style="list-style-type: none"> • Rod Steel 35 • Dia=30mm, Length=1000mm 	Nos	05	

14.	Nil	Material / Tools for fabrication of Sensor's body Country of Origin: Japan ,Eu or equivalent Specification: <ul style="list-style-type: none"> • Indexable Cutter Dia 18mm 2 flute with compatible insert (For Aluminum and Non Ferrous Alloy) as per drawing att at Anx-E 	Nos	2xtools 100xinserts	
15.	Nil	Material / Tools for fabrication of Sensor's body Country of Origin: Japan ,Eu Specification: <ul style="list-style-type: none"> • Solid Carbide Cutter Dia 6mm (2 flute), 	Nos	10	
16.	Nil	Material / Tools for fabrication of Sensor's body Country of Origin: Japan ,Eu or equivalent Specification: <ul style="list-style-type: none"> • Solid Carbide Cutter Dia 4mm (2 flute) 	Nos	05	
17.	Nil	Material / Tools for fabrication of Sensor's body Country of Origin: Japan ,Eu or equivalent Specification: <ul style="list-style-type: none"> • Machine Tap M4 Long (80mm) 	Nos	05	
18.	Nil	Material / Tools for fabrication of Sensor's body Country of Origin: Pakistan or equivalent Specification: <ul style="list-style-type: none"> • Upper & Lower Sealing Pad as per drawing att at Anx B 	Nos	54	
19.	Nil	Material / Tools for fabrication of Sensor's body Country of Origin: Pakistan or equivalent Specification: <ul style="list-style-type: none"> • Buffer pads Rubber as per drawing att at Anx C 	Nos	80	
20.	Nil	Material / Tools for fabrication of Sensor's body Country of Origin: Pakistan or equivalent Specification: <ul style="list-style-type: none"> • Sockets Sealing Pad as per drawing att at Anx D 	Nos	54	
21.	Nil	Material / Tools for fabrication of Sensor's body Country of Origin: Pakistan or equivalent Specification: <ul style="list-style-type: none"> • Steel Sheath • Thickness 0.1mm • Length: 5 Meter 	Nos	01	
22.	--	Paint: Primer Country of Origin: Pakistan or equivalent	Ltrs	20	

23.	--	Paint: Enamel Paint (Sea foam) Country of Origin: Pakistan or equivalent	Ltrs	20	
24.	--	Paint: Thinner Country of Origin: Pakistan or equivalent	Ltrs	10	

//

(Items Twenty Four Only)

Instructions to Bidders

2. Rates will be quoted on **FOR Taxila Cantt** basis. Offer best competitive price while submitting your quotation.

3. Over writing and cutting of any nature in the quotation will not be accepted.

4. Part-I and Part-II quotations will be enclosed in separate sealed envelopes for each tender inquiry. For identification purpose, the words "**TECHNICAL QUOTATION PART-I WITHOUT PRICE**" and **COMMERCIAL QUOTATION (PART-II) WITH PRICE**" shall be written in BLOCK CAPITAL LETTERS on the respective sealed envelopes which will be placed in a large envelope bearing complete details of the tender as under:-

Please forward your quotation not later than **26 Nov 2021** at **10:30 hours**. The address on the envelope will be indicated as under:-

BID

REGISTERED

TENDER INQUIRY NO. 5646/IT- 17/Proc/ARDIC dated 03 Nov 2021

TO BE OPENED ON. 26 Nov 2021

To: PROCUREMENT OFFICER
ARDIC HIT TAXILA CANTT

FROM M/S _____
IT FOR _____

5. **Delivery of Tender:** The tender/bid will be enclosed in a sealed envelope which will be invariably marked with "Bid against Tender Inquiry No. **5646/IT- 17/Proc/ARDIC dated 03 Nov 2021**" and complete address. The tender if brought by hand, will be handed over to security staff on duty at **ARDIC Gate for placing the same in bid box (available at the ARDIC Gate)**. The bid will not be brought by hand by any firm while visiting the office of Proc officer (ARDIC). Moreover if required endorsements are found missing, the bid will be liable for rejection.

6. The bid must be dropped in the bid box, latest by 1030 hours on **26 Nov 2021**, at ARDIC Gate. **The bid will be opened same day at 1100 hours** in the presence of the available representative of the firms in ARDIC HIT Taxila Cantt. **No bid will be entertained / considered after 1030 hours**, on the aforementioned date.

7. All papers must be signed and stamped and items not quoted / quoted must be mentioned clearly.

8. All clauses/terms mentioned in this inquiry will be considered accepted by the bidding firms, even if no reference to them is given in the respective offers.

9. **Postal order for Rs. 200/- (Rupees Two Hundred) as a tender fee, in favor of MD (ARDIC)** HIT Taxila Cantt, will invariably be enclosed with the technical offer, failing which the bid will be ignored.

10. Firms are instructed NOT to send Telex and Fax bids. Such bids/offers would not be accepted.

11. Please confirm receipt of the tender inquiry immediately and also intimate your participation or otherwise in this tender inquiry. In case any firm does not wish to bid, then it should return the tender inquiry documents at the earliest.

12. HIT reserves its right to cancel the bidding process with reason but without any obligation to justify such a reason.

13. The store is required to be delivered at Store Sec ARDIC, Taxila Cantt within 30 days from the date of signing of the contract.

14. The offered price quoted must be firm, final and inclusive of all taxes, packing, handling charges etc and delivery at HIT Taxila Cantt.

15. **Offers must remain open valid for 120 days** from the date of opening of the tender.

16. The store will be packed in standard grade, worthy of transportation by the means adopted.

17. This inquiry may not be taken as an indication of subsequent supply order and does not in any way commit HIT to purchase the items offered.

18. Warranty period will be one year from the date of issuance of CRV of the stores.

19. In case of failure to supply the stores within the stipulated periods, liquidated damages at the rate of 2% but not less than 1% of amount involved per month and maximum value not more than 10% of contracted store value or a part there-of will be levied.

20. **Payment Terms**

- a. Payments will be made either by CMA (DP), Rawalpindi or CMA (HIT) Taxila Cantt, through cheques against pre-receipted bills (duly affixed with revenue stamps) alongwith professional tax certificates (attested photocopies) of the suppliers after delivery and acceptance of stores.
 - b. Partial payments against partial deliveries will not be allowed.
 - c. The payment to the registered person is linked with active taxpayer status of the Suppliers as per FBR data base. If any registered supplier is not on active Taxpayer list, his payment will be stopped till he / she files his / her mandatory returns and appears on ATL of FBR.
21. HIT reserves the right to increase / decrease the quantity of items, placed on the tender without any reference to the firm.
22. The supplier shall furnish a 5% performance bank guarantee within one month from the date of signing of the contract from scheduled bank in Pakistan against the total value of contract excluding taxes/duties. This bank guarantee must remain valid 12 x months after the stores are put in operation. Performance Bank Guarantee will be released on the completion of warranty period, in case the firm fails to provide a/m performance bank guarantee within the stipulated time period, the contract will be cancelled and bid security will be encashed. Moreover, the contract shall than be awarded to next best evaluated bidder.
23. **All Firms participating in the tender will deposit 2% bid security of total quoted value in the shape of CDR / bank guarantee addressing to MD ARDIC Heavy Industries Taxila. The bid security will be provided by the firms in commercial envelope and clear mentioning of the same in the technical quotation will be ensured by the firms, failing which the bid will stand rejected. The bid securities will be returned as under:-**
- a. **Unsuccessful Bidders.** Within 15 days of completion/announcement of the bid evaluation result.
 - b. **Successful Bidders.** Upon submission of 5% PBG (para 22).
24. The net offered price will be inclusive of 17 % GST as imposed by Government of Pakistan. The offers without mentioning of 17% GST will not be considered. The GST will always be mentioned separately to the base price.
25. Defaulted or Blacklisted firms with any Govt / Semi Govt defence organization cannot be participate in the bid.
26. In case of any dispute regarding the terms and conditions and the quality of stores, the decision of the MD (ARDIC)/Chairman HIT will be considered as final and binding on the suppliers/firms.
27. In case, the contracted firm fails to execute the order within the stipulated time and does not materialize the supply of ordered stores, the supply order/contract would be cancelled at the firm's risk and expense. Expenditure incurred on the re-purchase of offered stores will be recovered from the defaulting firm, under existing procedures.
28. Inspection of the store will be carried out at HIT Taxila Cantt.
29. Only registered suppliers / persons who are on Active Taxpayer List (ATL) of FBR are eligible to supply goods/services to government departments. Thus the bidders will submit a certificate to this regard along with the technical bid.
30. Country of Origin: All countries except India, Israel and Taiwan.
31. In case of indigenously / locally manufactures item, the firms should have relevant experience and capacity of manufacturing these parts and should be duly qualified by Quality Control department of ARDIC HIT. Capacity for manufacturing of parts will be verified by a team ex ARDIC HIT.
32. In the case of FOR imported items, the firms are responsible to provide evidence of the agency agreement/certificate of conformance, principal proforma invoice (in original and without price) and OEM certificates of all the items being quoted against this tender inquiry along with countries of origin. Separate OEM certificate for each / major assembly will be provided by the firms. The firms will clearly indicate that all the parts used in the manufacturing (in case of assembling) are brand new from current production. Confirmation to fulfill technical specifications related to imported items on FOR basis must be highlighted in the technical bid.
33. Confirmation of the validity period of the quote, delivery period and warranty period.
34. Confirmation of all technical parameters specified in the IT.
35. Confirmation of manufacturer, brand and approval of advance sample as per specifications mentioned in IT. Manufacturer brand of each item must be highlighted in the bid.
36. IT document can be downloaded from PPRA and HIT website www.hit.gov.pk

General Notes:
Shore Hardness 41-43

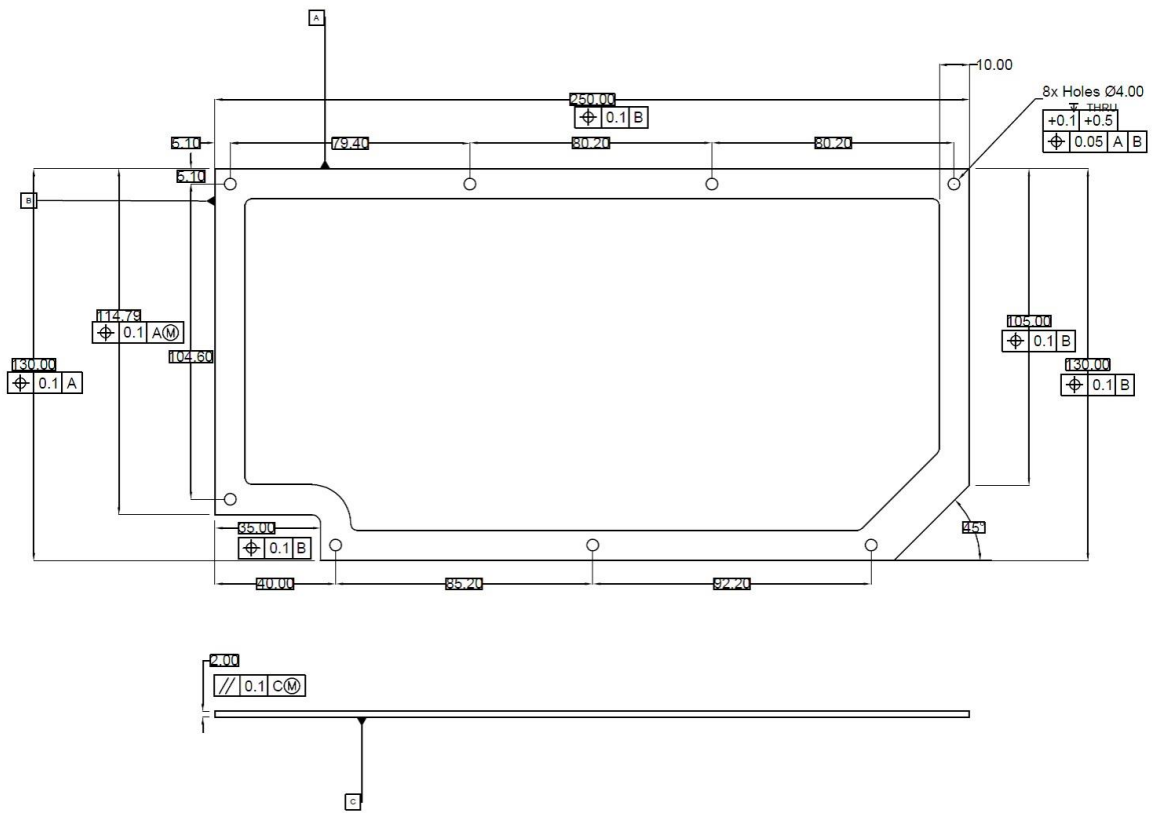

			MODEL NUMBER	YV0012A.0302-3	REVISION
			DESCRIPTION	UPPER AND LOWER SEALING PAD	
GENERAL TOLERANCES UNLESS SPECIFIED			TREATMENT/COATING	Si RUBBER	THIRD ANGLE PROJECTION
XX.XX ±1 MM			SCALE	MODEL TYPE	DATE
XXX.XX ±2 MM			NTS	2D/3D	SHEET
					15 of 16

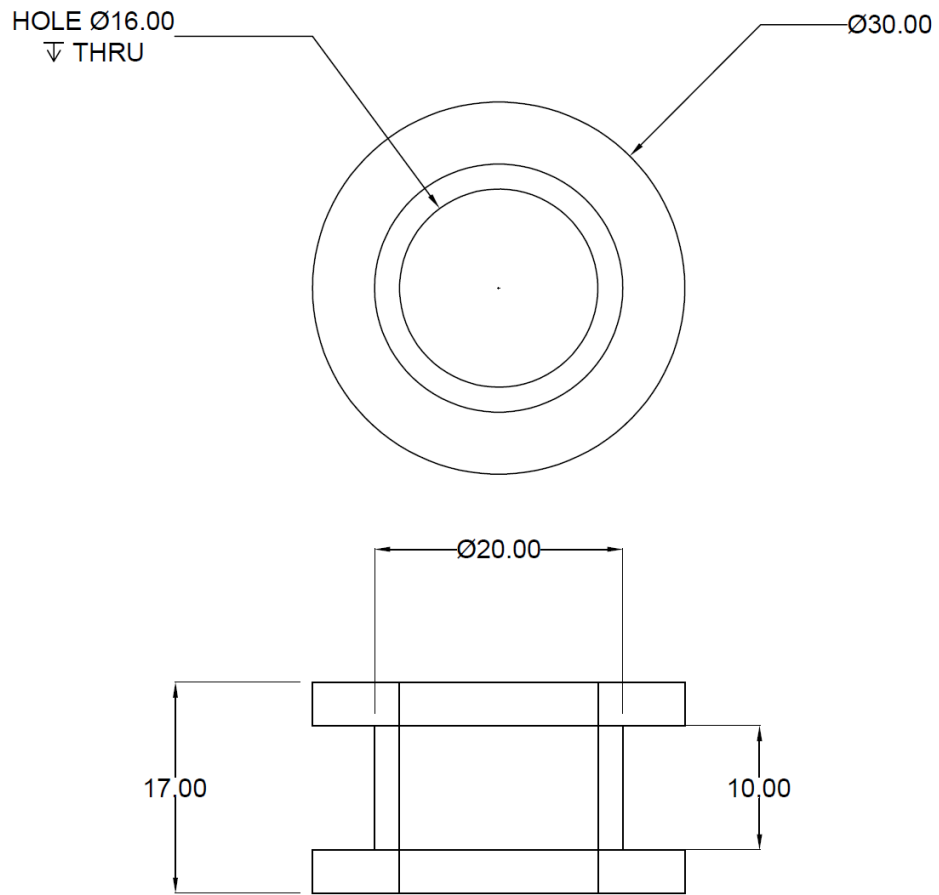

			MODEL NUMBER	YV0012A.0302-7	REVISION
			DESCRIPTION	BUFFER PAD	
GENERAL TOLERANCES UNLESS SPECIFIED			TREATMENT/COATING	RUBBER	THIRD ANGLE PROJECTION
X.XX ±0.25 MM					
XX.XX ±0.5 MM			SCALE	MODEL TYPE	DATE
			NTS	2D/3D	SHEET
					14 of 16

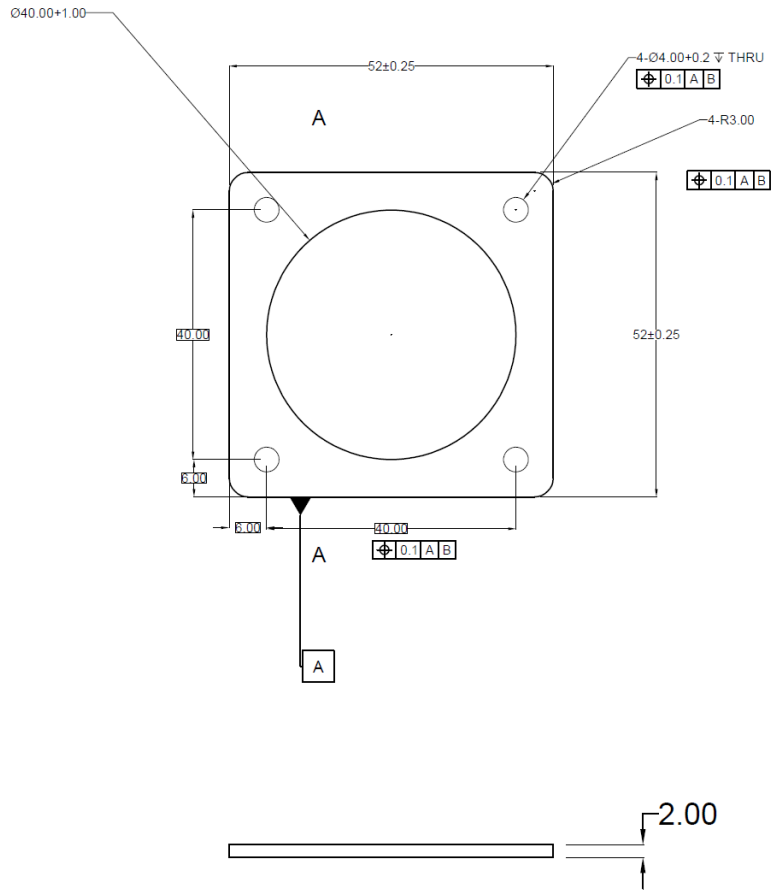

			MODEL NUMBER	REVISION
			YV0012A.0302-16	
			DESCRIPTION	
			SOCKETS SEALING PAD	
GENERAL TOLERANCES UNLESS SPECIFIED			TREATMENT/COATING MAT	THIRD ANGLE PROJECTION
X.XX ± 0.25 MM			Si RUBBER	
XX.XX ± 0.5 MM			SCALE	MODEL TYPE DATE
XXX.XX ± 1 MM			NTS	2D/3D SHEET
				16 of 16

Indexable Cutter Dia 18mm 2 flute with compatible insert

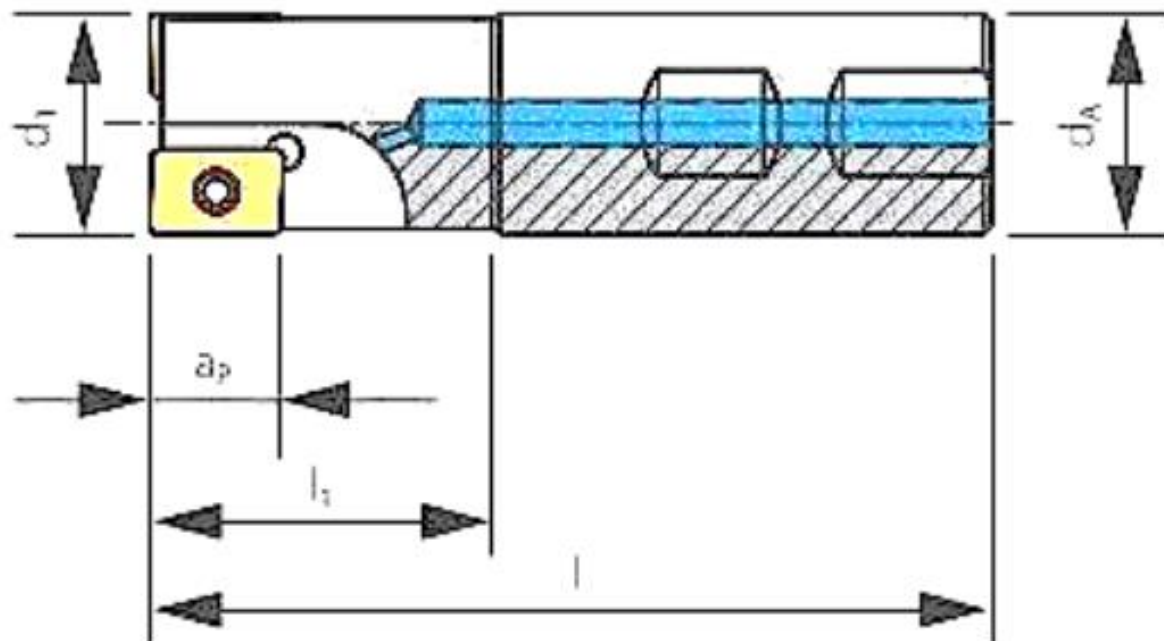

$d_1 = 18\text{mm}$
 $d_A = 16\text{mm}$
 $L = 150\text{mm}$
 $L_2 = 25\text{mm}$